

THE GAS TEST GAUGE MUST BE ACCURATE TO $\frac{1}{10}$ OF ONE AND MUST HOLD FOR AT LEAST 15 MINUTES WITH NO PERCEPTIBLE DROP IN PRESSURE WHILE THE INSPECTOR IS ON SITE.

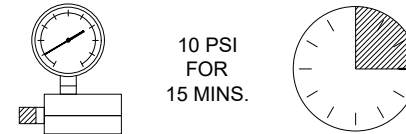

* SHUTTING OFF (E) VALVES IS NOT SUITABLE FOR TESTING AS EXCESSIVE PRESSURE CAN DAMAGE THE EXISTING SHUT OFF VALVES REQUIRING REPLACEMENT*

GAS LINE TEST

WATER EFFICIENT PLUMBING FIXTURES REQUIRED:

FIXTURE(S)	NON-COMPLIANT FLOW RATE	UPGRADE TO: (MAX. FLOW RATES)
WATER CLOSET	> 1.6 GAL/FLUSH	1.28 GAL/FLUSH
SHOWERHEAD	@ 80 PSI > 2.5 GAL/MIN	2.00 GAL/MIN
BATH FAUCET	@ 60 PSI > 2.2 GAL/MIN	1.20 GAL/MIN
KITCHEN FAUCET	@ 60 PSI > 2.2 GAL/MIN	1.80 GAL/MIN

CONSTRUCTION NOTES:

1. WATER PIPE PLUMBING IS PROHIBITED IN EXTERIOR WALLS
2. ALL EXTERIOR WALLS/ROOFS/CEILINGS EXPOSED DURING CONSTRUCTION SHALL BE INSULATED
3. IT IS UNLAWFUL TO CONCEAL CRACKS, HOLES, OR OTHER IMPERFECTIONS IN MATERIALS BY WELDING, BRAZING, OR SOLDERING, OR BY USING THEREIN OR THEREON A PAINT, WAX, TAR, SOLVENT CEMENT, OR OTHER LEAK-SEALING OR REPAIR AGENT
5. ALL JOINTS, PENETRATIONS, AND OTHER OPENINGS IN THE BUILDING ENVELOPE ABOUT THE AREA OF WORK SHALL BE CAULKED, WEATHER STRIPPED, OR OTHERWISE SEALED

LIFE SAFETY NOTES:

1. SMOKE AND CARBON MONOXIDE ALARMS, WITH 10 YEAR BATTERY AND SFM LISTED, SHALL BE INSTALLED ON THE CEILING OR WALL AT:
 - SLEEPING ROOMS
 - AREA/HALLWAY(S) ADJACENT TO SLEEPING ROOMS
 - EACH STORY OF THE BUILDING
 - BASEMENT

ELECTRICAL NOTES:

1. COUNTERTOP RECEPTACLES SHALL BE PROTECTED WITH GROUND FAULT CURRENT INTERRUPTER (GFCI)
2. ALL RECEPTACLES SHALL BE TAMPER RESISTANT
3. A MINIMUM TWO 20-AMP DEDICATED KITCHEN COUNTER CIRCUITS ARE REQUIRED
4. ALL KITCHEN COUNTER RECEPTACLES SHALL BE GFCI AND ARC FAULT PROTECTED
5. DISHWASHERS, GARBAGE DISPOSALS, TRASH COMPACTORS, BUILT-IN MICROWAVE OVENS, AND KITCHEN LIGHTING SHALL BE ON THEIR OWN CIRCUITS
6. DISHWASHERS MUST BE GFCI PROTECTED
7. MULTI-WIRE DUPLEX RECEPTACLES FOR GARBAGE DISPOSALS AND DISHWASHERS REQUIRE TIE-BARS AT THE SERVICE PANEL BREAKER

LIGHTING EFFICIENCY NOTES:

1. ALL LIGHTING FIXTURES SHALL BE CONTROLLED BY EITHER A DIMMER SWITCH OR BY A VACANCY SENSOR SWITCH THAT REQUIRES A MANUAL ON ACTIVATION AND AUTOMATICALLY TURNS OFF WITHIN 20 MINUTES AFTER THE ROOM IS VACATED
2. ALL LIGHT FIXTURES SHALL CONTAIN BULBS THAT ARE LABELED AS JA8-2016 (JA8-2016-E FOR SEALED LENS OR RECESSED FIXTURE). SCREW BASED BULBS IN RECESSED CANS ARE NOT ALLOWED

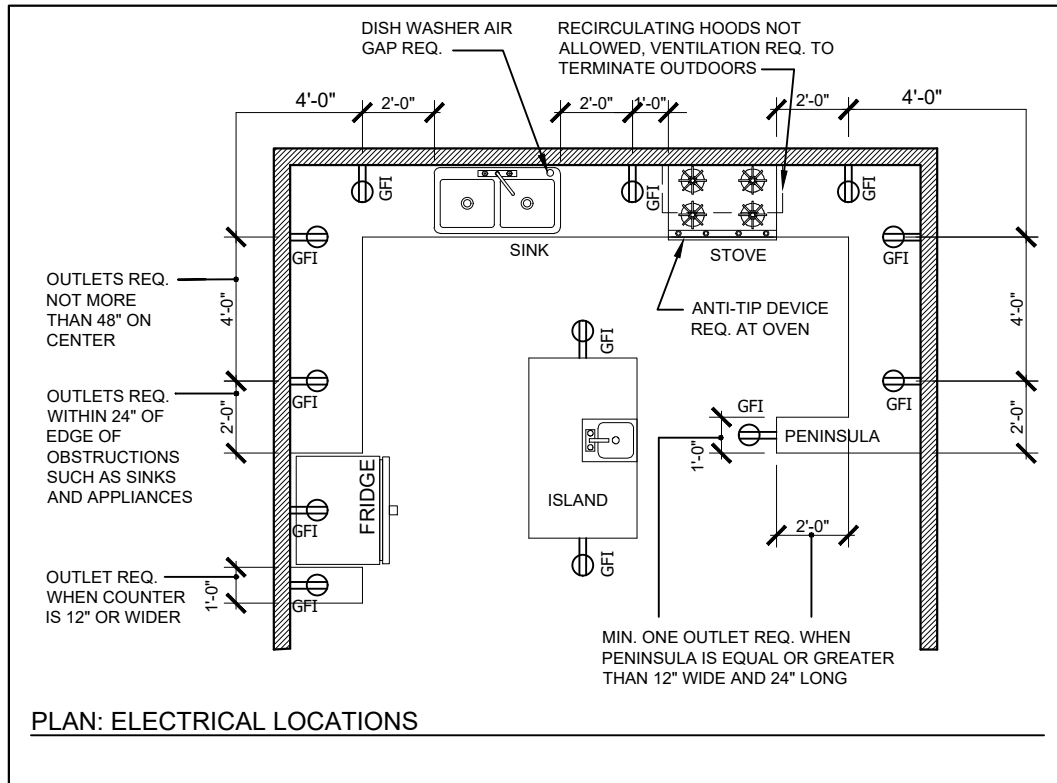

**RESIDENTIAL KITCHEN REMODEL
TIP SHEET**

